

LOS ANGELES HARBOR AREA CEMETERY DISTRICT
Meeting of the Board of Trustees
Wednesday, July 6, 2022, at 6:00 p.m.
605 E. O St. Wilmington, CA. 90744

Historic Wilmington Cemetery
Board of Trustees

Sergio Carrillo, President
Loraine F. Geluz, Vice President
Tony Fernandez, Secretary
Carol Maldonado, Trustee
Theresa M. Morales, Trustee

AGENDA

This agenda has been prepared and posted at least 72 hours prior to the Regular Meeting of the Board of Trustees in accordance with the Ralph M. Brown Act.

The public may be heard on an item before or during the consideration of any agenda item to be considered by the Board of Trustees, subject to reasonable time limitations for each speaker.

The Board of Trustees CANNOT act on any unscheduled items unless it is declared by a vote of at least two thirds (2/3) of the Board that there is an urgent need to take immediate action, and the need for action came to the attention of the district after the agenda was posted. Agenda items are numbered for identification purposes only and will not necessarily be considered in the indicated order.

All items on this agenda, whether expressly listed for action, may be deliberated and may be subject to action by the Board of Trustees. Details and supporting materials concerning agenda items are available for public reference during normal working hours at the District Office.

1) CALL TO ORDER, ROLL CALL AND ESTABLISHMENT OF QUORUM

2) CERTIFICATION OF AGENDA POSTING

3) FLAG SALUTE

4) ACTION ITEMS, DISCUSSION & POSSIBLE ACTION

5) DISINTERMENT POLICY *(This policy applies to the disinterment of human remains, which includes the body of a deceased person, regardless of its stage of decomposition, and cremated remains, at an interment site), We have a family that wants to disinter their grandmother.*

6) STATUS ON FLAGPOLE PERMIT *(see attach)*

7) UPDATE ON PAVING OF EMPTY LOT AND CUTTING OF PALM TREE BY WALTON CONSTRUCTION. WHEN THEY ARE GOING TO START. *(see attach)*

8) LOWERING DEVICE UPDATE *(see attach)*

9) REPLACING OF FENCE & TRIMMING OF BUSHES ALONG FENCE BY RAILROAD.

10) RECEIVE AND FILE ENGINEER’S REPORT REGARDING ANNUAL ASSESSMENT FOR LANDSCAPE MAINTENANCE PURPOSES PURSUANT TO PROVISIONS OF THE LANDSCAPE AND LIGHTING ACT OF 1972

On August 3, 1987 by action of the Board of Trustees of the Wilmington Cemetery District of the County of Los Angeles, a Resolution was adopted to form an assessment district for landscape maintenance purposes pursuant to provisions of the Landscaping and Lighting Act of 1972, being part of Division 15 of the Streets and Highway Code of the State of California. In order to provide funds for the continued operations and landscape maintenance services provided by the existing Wilmington Cemetery Facility, said code requires an Engineer’s Report to be submitted prior to the adoption of a Resolution of Intention to levy and collect the annual assessments.

11) PUBLIC HEARING

Conduct a Public Hearing on the proposal to levy and collect annual assessments for Fiscal Year **0000-00** for Wilmington Cemetery District LLA District 1 pursuant to provisions of the Landscape and Lighting Act of 1972 (Division 15, Part 2, Streets and Highways Code, State of California) and receive supporting documentation into the record.

12) RESOLUTION TO ACCESS, ORDER, LEVY AND COLLECT ANNUAL ASSESSMENTS FOR FISCAL YEAR 2019-20 FOR WILMINGTON CEMETERY DISTRICT LLA DISTRICT 1.

The Board of Trustees orders the assessments, levy and collection of the assessments of **\$000,000** against **0,000** parcels at a rate of **\$00.00** per parcel and three public utility parcels at **\$000.00** per parcel.
(Figures in RED will be added in addendum to this agenda later)

13) CLOSED SESSION (IF ANY OTHERWISE WILL REMOVE FROM THIS AGENDA)

14) NEXT MEETING FOR 6:00 PM WEDNESDAY AUGUST 3, 2022, AT WILMINGTON HISTORIC CEMETERY

Item 6 FLAGPOLE REPLACEMENT

a) Flagpole project, possible placement of new flagpole site is far middle of the cemetery facing ICE container where there are 3 stationary yellow cautionary poles are located. **b)** There are ongoing several quotes being requested. **c)** Ongoing conversation has started with Sergio and the Office Supervisor Hahn for assistance. **d)** Tony Fernandez email sent to Department of Building Service and **e)** Department of Public Works for the process on permit has come to light a permit maybe required. Sergio Carrillo had tried to get information with Department of Building and Safety San Pedro in person but needed to make an appointment. **f)** Tony Fernandez had a Google Meet Tuesday 05/10/2022 with Fernando Navarrete Field Deputy for CD15. Fernando will provide the language for the Board to confirm and have on file but in short if we repair/replace it ourselves since its private property there is no need for permit. If we hire or have someone install it, then it needs a permit and other documents. Request further discussion on this item.







The Flagpole Company
The Flagpole Professionals
Est. 2000

Flagpole & Flag Size Chart







15ft
3'x5'



20ft
3'x5'



25ft
4'x6'



30ft
5'x8'



35ft
6'x10'



40ft
8'x12'



50ft
10'x15'



60ft
12'x18'



70ft
15'x25'



80ft
20'x30'

I want to fly to 2 flags.

20ft = 3'x5' & 3'x5'	25ft = 3'x5' & 3'x5'
30ft = 4'x6' & 3'x5'	35ft = 5'x8' & 4'x6'
40ft = 6'x10' & 5'x8'	45ft = 6'x10' & 5'x8'
50ft = 8'x12' & 6'x10'	60ft = 10'x15' & 6'x10'
70ft = 12'x18' & 8'x12'	80ft = 15'x25' & 12'x18'

Residential

- Average height for small home / limited space: 15ft
- Average height for a single story home: 20ft
- Average height for a 2 story home: 25ft
- Average height for an estate home: 30ft

Commercial

- Average height for standard commercial bldg: 25ft & 30ft
- Average height for a large commercial bldg: 35ft & 40ft
- Average height for a corporate complex: 40ft, 50ft & 60ft
- Average height for carwash, gas station's & dealerships: 60ft, 70ft & 80ft

Landmark Series Flagpoles: Dealerships, Storage Facilities & More : 100ft thru 200ft

Item 6 FLAGPOLE REPLACEMENT (continued)

Current lead time for flagpoles 30' & longer may take 4 to 8 weeks for delivery due to LTL delivery driver shortages.

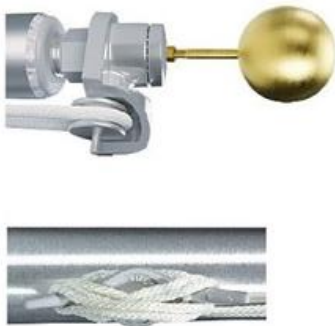
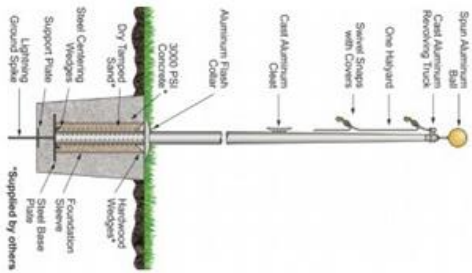

Setting the Standard, Traditional #1 Choice in the Industry!

- Revolving truck assembly.
- Truck swivels back & forth with flag.
- Low maintenance.
- Perfect for flag raising ceremonies.
- Traditional / Classic.
- Superior strength & beauty.
- Our most popular choice!
- Ships common carrier freight.
- Made in the USA.
- Lifetime shaft warranty, restrictions may apply.

Two Steps to Buying an External Halyard Aluminum Flagpole

- 1) Choose **Exposed Height**: 20ft to 80ft, using [Flagpole Size Chart](#)
- 2) Choose **Strength/Wind Load** using [Wind Speed Chart](#)

Item 6 FLAGPOLE REPLACEMENT (continued)

Application	Material	Type	Exposed Height	Strength/Wind Load
Showing 1 - 39 of 39 items				Sort By: Price low to high
	20ft (1) Piece Wind Speed 120+ Mph & Butt Dia. x 188 Wall Thickness External Hayward Aluminum Flagpole	Flagpole		Regular: \$1712.06 Sale Price: \$1652.95
	20ft (1) Piece Wind Speed 109 Mph & Butt Dia. x 125 Wall Thickness External Hayward Aluminum Flagpole	Flagpole		Regular: \$1426.06 Sale Price: \$1375.95
	20ft (1) Piece Wind Speed 136 Mph & Butt Dia. x 125 Wall Thickness External Hayward Aluminum Flagpole	Flagpole		Regular: \$1620.06 Sale Price: \$1490.95
	20ft (1) Piece Wind Speed 182 Mph & Butt Dia. x 188 Wall Thickness External Hayward Aluminum Flagpole	Flagpole		Regular: \$2422.06 Sale Price: \$2372.95
	20ft (1) Piece Wind Speed 89 Mph & Butt Dia. x 125 Wall Thickness External Hayward Aluminum Flagpole	Flagpole		Regular: \$1490.06 Sale Price: \$1649.95
	25ft (1) Piece Wind Speed 105 Mph & Butt Dia. x 125 Wall Thickness External Hayward Aluminum Flagpole	Flagpole		Regular: \$1927.06 Sale Price: \$1927.95
	26ft (1) Piece Wind Speed 120 Mph & Butt Dia. x 150 Wall Thickness External Hayward Aluminum Flagpole	Flagpole		Regular: \$2422.06 Sale Price: \$2372.95
	26ft (1) Piece Wind Speed 120+ Mph & Butt Dia. x 188 Wall Thickness External Hayward Aluminum Flagpole	Flagpole		Regular: \$2422.06 Sale Price: \$2372.95

Item 6 FLAGPOLE REPLACEMENT (continued)

passion-district.com

☰ 🔗 🔍 🛒³



**Solar Powered Flagpole Light
- All Night Long Last - LED**

\$64.90 ~~\$84.90~~ **SAVE \$20.00**

QUANTITY

We use cookies to ensure that we give you the best experience on our website. If you continue we'll assume that you understand this. [Learn more](#)

Item 7 PAVING OF EMPTY LOT AND CUTTING OF PALM TREE BY WALTON CONSTRUCTION



me 10:33 AM
Angel, Hope you're doing well and your summer is off t...

Angel Orozco 10:45 AM
to me, Gary, jacob.haik@lacity.org, Gor... ▾

Hey Fernando,

We received pricing for this last week. We are moving forward with doing basic grading and adding base at cemetery parking lot for Walton to use as temporary parking and turn over to the cemetery at a later date. Gary will be in touch with directors at the cemetery and our graders regarding the start of the parking lot work.

...



me 10:46 AM
to Angel, Gary, Gordon, jacob.haik@lac... ▾

Thank you for the update. I'll update the cemetery commission. Feel free to call or text with any questions: (c) 424-215-1159.

...

Sent. Undo

638 S. Beacon Street, San Pedro CA, 90731
O: 310-732-4515

American Cemetery Supplies

15' x 15' SOFT TOP ROLL-AROUND



\$1,995

**Top &
Steel Frame
\$1,995.00**

**Pulling Device
\$345.00**

- Acrylic Fabric
- Pneumatic Tire Wheels
- Side Walls Available
- Also Available in 15x20 and 20x20

14' x 20' HARD TOP CHAPEL

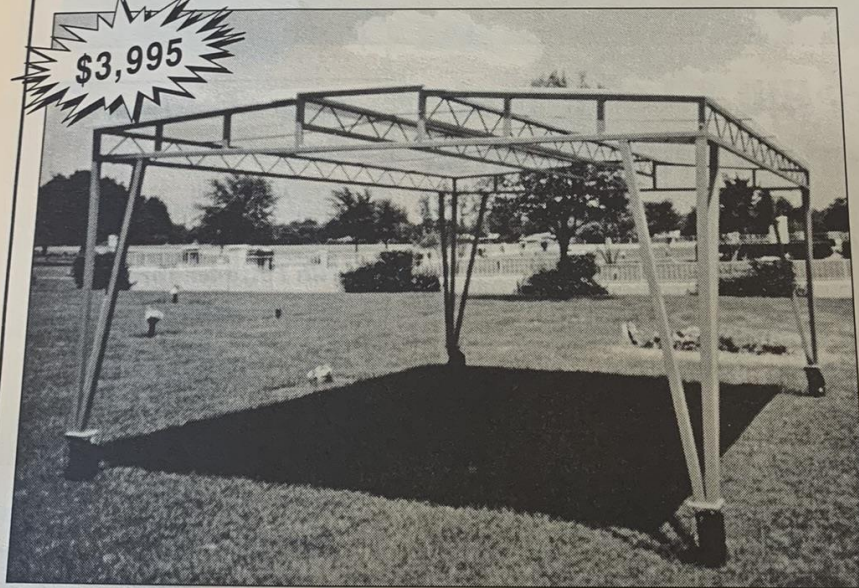

\$3,995

**Top &
Steel Frame
\$3,995.00**

- 1 Heavy Gauge All-Steel Post, Fiberglass Top
- Pneumatic Tire Wheels
- Side Curtains Available
- Pulling Device Available

1-800-515-0400

Concrete Vault Lid Placer

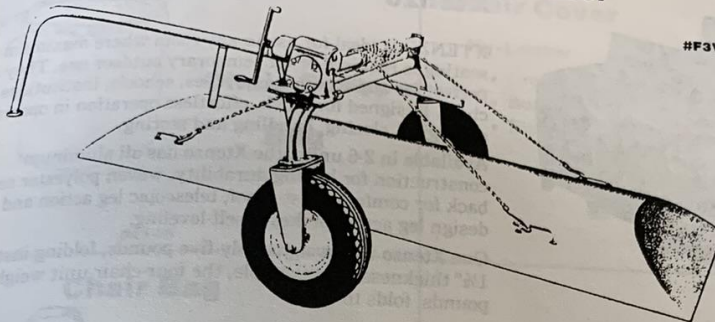

#F3VLPF58

Vault Probes



#5144

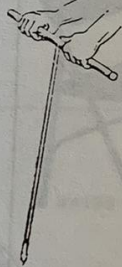

**Vault Lowering Device
Corner Covers**

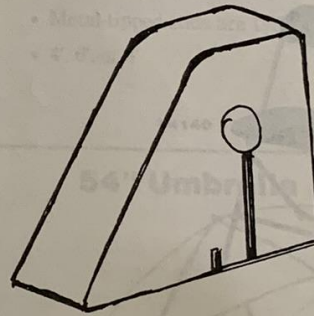

#4199

Vault Lowering Device

One man can easily transport, set-up and use burial vault lowering device, quickly, efficiently and safely

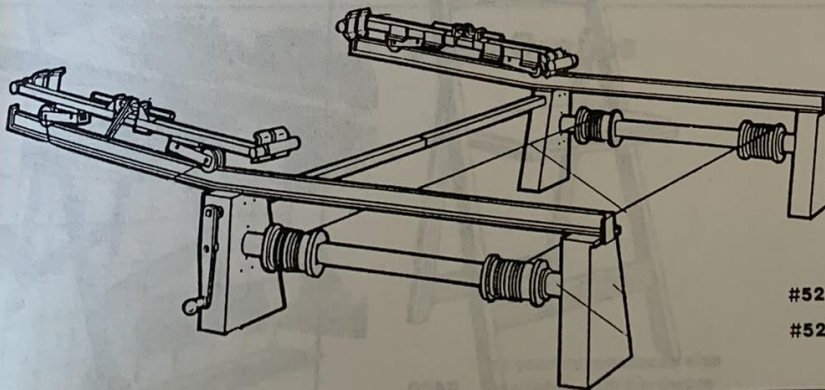

#5240/5244 Stainless Steel
#5241/5245 Painted