

**LOS ANGELES HARBOR AREA CEMETERY DISTRICT
Meeting of the Board of Trustees**

Wednesday, September 7, 2022, at 6:00 p.m.

In person
605 E. O St.
Wilmington, CA.90744

Google Meet
meet.google.com/pob-cqge-vge
Dial-in: (US) +1 413-648-7978
PIN: 515 490 653#

**Historic Wilmington Cemetery
Board of Trustees**

Sergio Carrillo, President
Loraine F. Geluz, Vice President
Tony Fernandez, Secretary
Carol Maldonado, Trustee
Theresa M. Morales, Trustee

AGENDA

This agenda has been prepared and posted at least 72 hours prior to the Regular Meeting of the Board of Trustees in accordance with the Ralph M. Brown Act.

The public may be heard on an item before or during the consideration of any agenda item to be considered by the Board of Trustees, subject to reasonable time limitations for each speaker.

The Board of Trustees CANNOT act on any unscheduled items unless it is declared by a vote of at least two thirds (2/3) of the Board that there is an urgent need to take immediate action, and the need for action came to the attention of the district after the agenda was posted. Agenda items are numbered for identification purposes only and will not necessarily be considered in the indicated order.

All items on this agenda, whether expressly listed for action, may be deliberated and may be subject to action by the Board of Trustees. Details and supporting materials concerning agenda items are available for public reference during normal working hours at the District Office.

1) CALL TO ORDER, ROLL CALL AND ESTABLISHMENT OF QUORUM

2) CERTIFICATION OF AGENDA POSTING

3) FLAG SALUTE

4) ACTION ITEMS, DISCUSSION & POSSIBLE ACTION

5) NO MEETING JULY 6, 2022

6) STATUS ON FLAGPOLE PERMIT *(see attach)*

7) DIAS DE LOS MUERTOS EVENT SATURDAY OCTOBER 29, 2022

8) LOWERING DEVICE UPDATE *(see attach)*

9) REPLACING OF FENCE & TRIMMING OF BUSHES ALONG FENCE BY RAILROAD.

10) CHRISTMAS DECORATION POLICY

11) CLOSED SESSION *(IF ANY OTHERWISE WILL REMOVE FROM THIS AGENDA)*

12) NEXT MEETING FOR 6:00 PM WEDNESDAY OCTOBER 5, 2022, AT WILMINGTON HISTORIC CEMETERY OR GOOGLE MEET

Item 6 FLAGPOLE REPLACEMENT

a) Flagpole project, possible placement of new flagpole site is far middle of the cemetery facing ICE container where there are 3 stationary yellow cautionary poles are located. **b)** There are ongoing several quotes being requested. **c)** Ongoing conversation has started with Sergio and the Office Supervisor Hahn for assistance. **d)** Tony Fernandez email sent to Department of Building Service and **e)** Department of Public Works for the process on permit has come to light a permit maybe required. Sergio Carrillo had tried to get information with Department of Building and Safety San Pedro in person but needed to make an appointment. **f)** Tony Fernandez had a Google Meet Tuesday 05/10/2022 with Fernando Navarrete Field Deputy for CD15. Fernando will provide the language for the Board to confirm and have on file but in short if we repair/replace it ourselves since its private property there is no need for permit. If we hire or have someone install it, then it needs a permit and other documents. Request further discussion on this item.







The Flagpole Company
The Flagpole Professionals
Est. 2000

Flagpole & Flag Size Chart







15ft
3'x5'



20ft
3'x5'



25ft
4'x6'



30ft
5'x8'



35ft
6'x10'



40ft
8'x12'



50ft
10'x15'



60ft
12'x18'



70ft
15'x25'



80ft
20'x30'

I want to fly to 2 flags.

20ft = 3'x5' & 3'x5'	25ft = 3'x5' & 3'x5'
30ft = 4'x6' & 3'x5'	35ft = 5'x8' & 4'x6'
40ft = 6'x10' & 5'x8'	45ft = 6'x10' & 5'x8'
50ft = 8'x12' & 6'x10'	60ft = 10'x15' & 6'x10'
70ft = 12'x18' & 8'x12'	80ft = 15'x25' & 12'x18'

Residential

- Average height for small home / limited space: 15ft
- Average height for a single story home: 20ft
- Average height for a 2 story home: 25ft
- Average height for an estate home: 30ft

Commercial

- Average height for standard commercial bldg: 25ft & 30ft
- Average height for large commercial bldg: 35ft & 40ft
- Average height for a corporate complex: 40ft, 50ft & 60ft
- Average height for carwash, gas station's & dealerships: 60ft, 70ft & 80ft

Landmark Series Flagpoles: Dealerships, Storage Facilities & More : 100ft thru 200ft

Item 6 FLAGPOLE REPLACEMENT (continued)

Current lead time for flagpoles 30' & longer may take 4 to 8 weeks for delivery due to LTL delivery driver shortages.

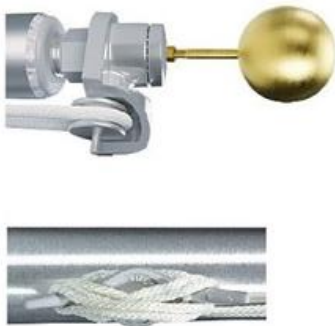
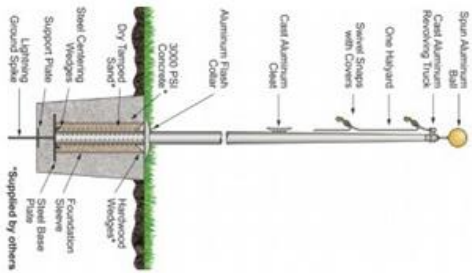

Setting the Standard, Traditional #1 Choice in the Industry!

- Revolving truck assembly.
- Truck swivels back & forth with flag.
- Low maintenance.
- Perfect for flag raising ceremonies.
- Traditional / Classic.
- Superior strength & beauty.
- Our most popular choice!
- Ships common carrier freight.
- Made in the USA.
- Lifetime shaft warranty, restrictions may apply.

Two Steps to Buying an External Halyard Aluminum Flagpole

- 1) Choose **Exposed Height**: 20ft to 80ft, using [Flagpole Size Chart](#)
- 2) Choose **Strength/Wind Load** using [Wind Speed Chart](#)

Item 6 FLAGPOLE REPLACEMENT (continued)

Application	Material	Type	Exposed Height	Strength/Wind Load
Showing 1 - 39 of 39 items				Sort By: <input type="text" value="Price low to high"/>
	20ft (1) Piece Wind Speed 120+ Mph 8 Butt Dia. x 188 Wall Thickness External Hayward Aluminum Flagpole	Flagpole		Regular: \$1712.06 Sale Price: \$1652.95
	20ft (1) Piece Wind Speed 100 Mph 4 Butt Dia. x 125 Wall Thickness External Hayward Aluminum Flagpole			Regular: \$1426.06 Sale Price: \$1373.95
	20ft (1) Piece Wind Speed 130 Mph 5 Butt Dia. x 125 Wall Thickness External Hayward Aluminum Flagpole			Regular: \$1620.06 Sale Price: \$1490.95
	20ft (1) Piece Wind Speed 182 Mph 5 Butt Dia. x 188 Wall Thickness External Hayward Aluminum Flagpole			Regular: \$2422.06 Sale Price: \$2373.95
	25ft (1) Piece Wind Speed 88 Mph 4 Butt Dia. x 125 Wall Thickness External Hayward Aluminum Flagpole			Regular: \$1400.06 Sale Price: \$1349.95
	25ft (1) Piece Wind Speed 106 Mph 5 Butt Dia. x 125 Wall Thickness External Hayward Aluminum Flagpole			Regular: \$1620.06 Sale Price: \$1527.95
	25ft (1) Piece Wind Speed 130 Mph 5 Butt Dia. x 150 Wall Thickness External Hayward Aluminum Flagpole			Regular: \$1922.06 Sale Price: \$1873.95
	25ft (1) Piece Wind Speed 120+ Mph 8 Butt Dia. x 188 Wall Thickness External Hayward Aluminum Flagpole			Regular: \$2422.06 Sale Price: \$2373.95

Item 6 FLAGPOLE REPLACEMENT (continued)

passion-district.com



< >



**Solar Powered Flagpole Light
- All Night Long Last - LED**

\$64.90 ~~\$84.90~~ **SAVE \$20.00**

QUANTITY

We use cookies to ensure that we give you the best experience on our website. If you continue we'll assume that you understand this. [Learn more](#)



AMERICAN CEMETERY SUPPLIES

1-800-515-0400

SATISFACTION — QUALITY — SERVICE

TENTS

DRAPES

LOWERING DEVICES

TARPS

GRASS

CHAIR COVERS

UMBRELLA'S

CHAIRS

FERNO — FRIGID — STERIL

happy in case you want to see what's available

Ermy

& DOTTAS

American Cemetery Supplies

15' x 15' SOFT TOP ROLL-AROUND



\$1,995

**Top &
Steel Frame
\$1,995.00**

**Pulling Device
\$345.00**

- Acrylic Fabric
- Pneumatic Tire Wheels
- Side Walls Available
- Also Available in 15x20 and 20x20

14' x 20' HARD TOP CHAPEL

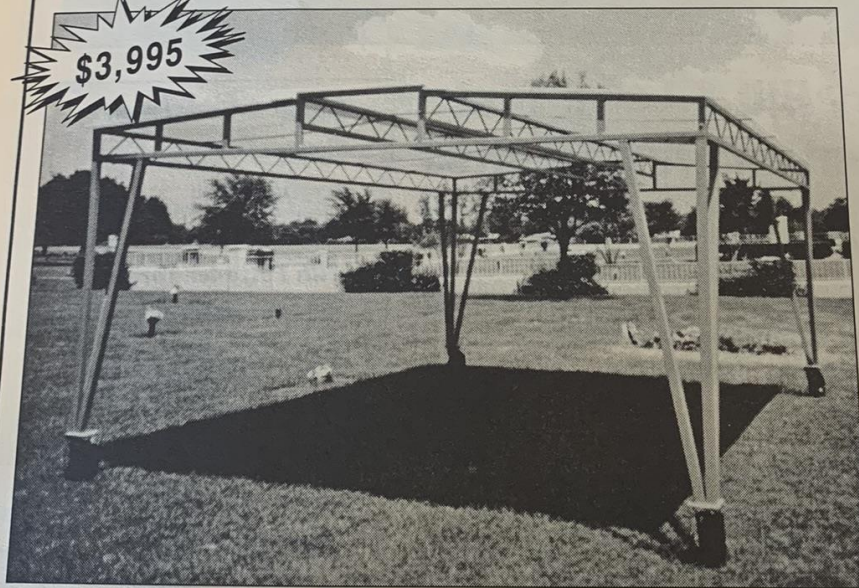

\$3,995

**Top &
Steel Frame
\$3,995.00**

- 1 Heavy Gauge All-Steel Post, Fiberglass Top
- Pneumatic Tire Wheels
- Side Curtains Available
- Pulling Device Available

1-800-515-0400

Concrete Vault Lid Placer

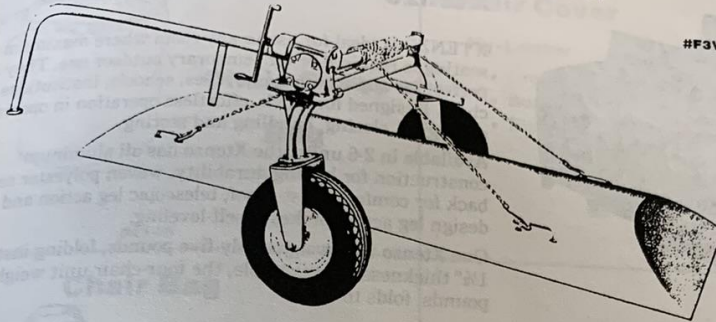

#F3VLPF58

Vault Probes



#5144

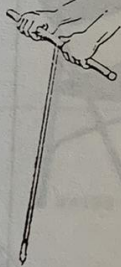

**Vault Lowering Device
Corner Covers**

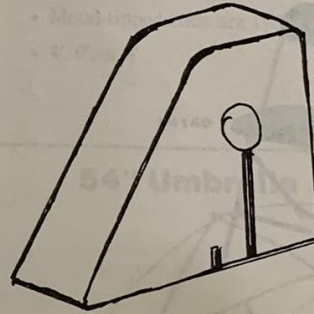

#4199

Vault Lowering Device

One man can easily transport, set-up and use burial vault lowering device, quickly, efficiently and safely

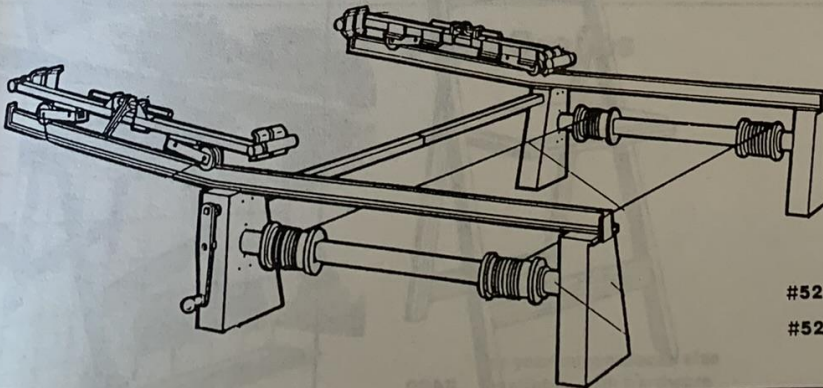

#5240/5244 Stainless Steel
#5241/5245 Painted